

**Connection between RF and Baseband modules** (Version 0410 Edit 2) for layout version 19

RF BASEBAND

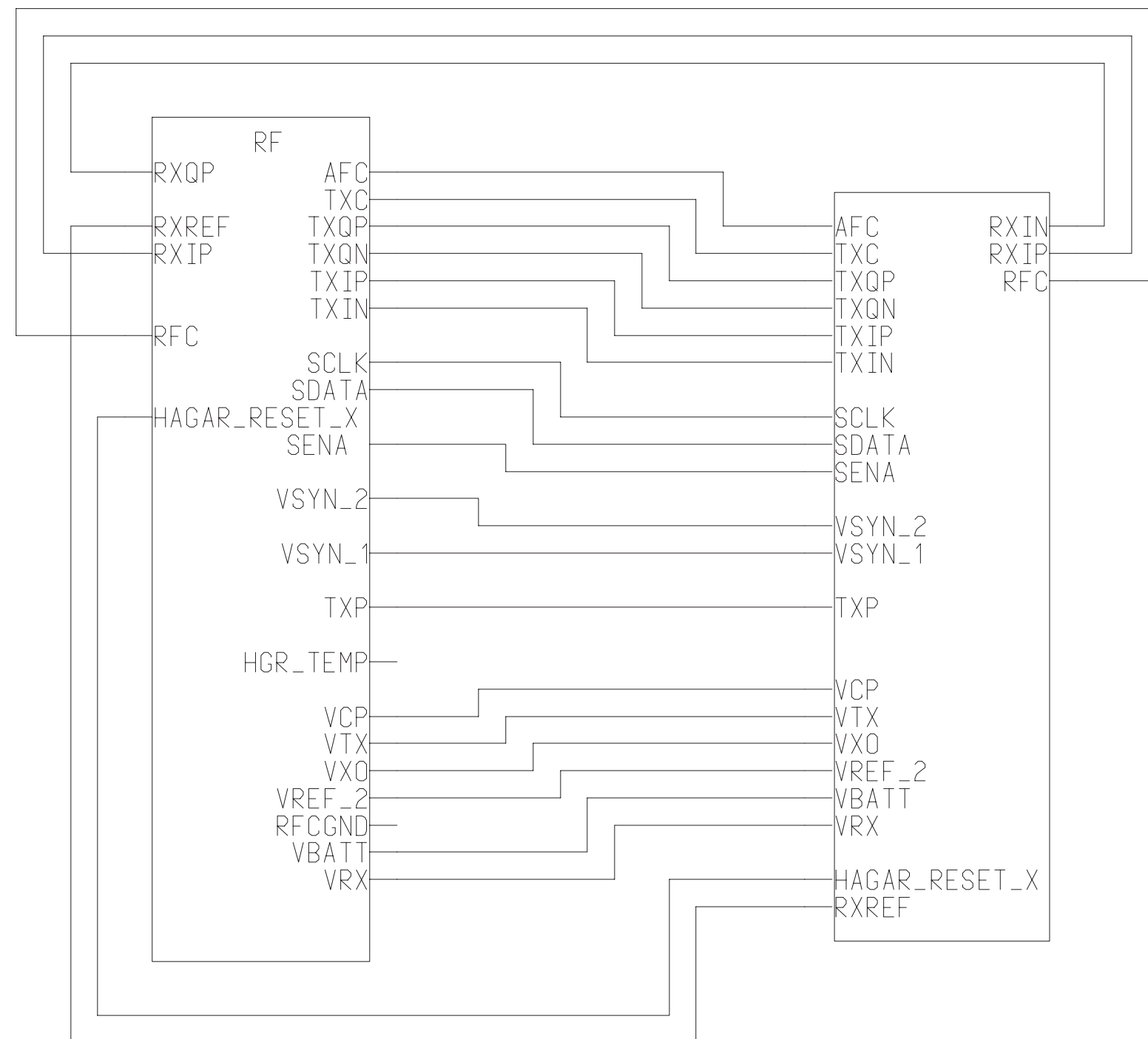

**Baseband Block Interconnections** (Version 0410 Edit 2) for layout version 19

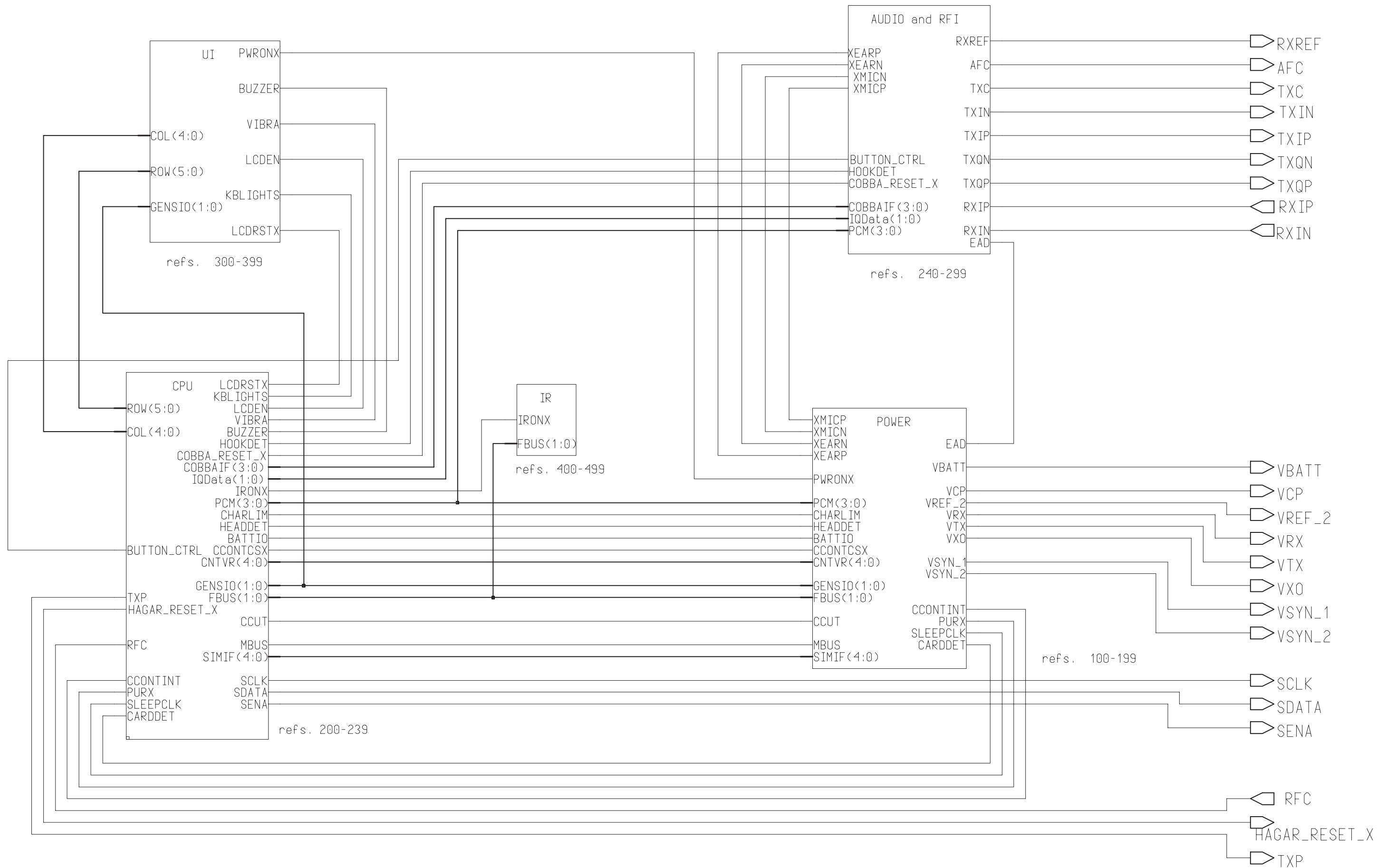

**Circuit Diagram of Power Supply** (Version 0410 Edit 2) for layout version 19

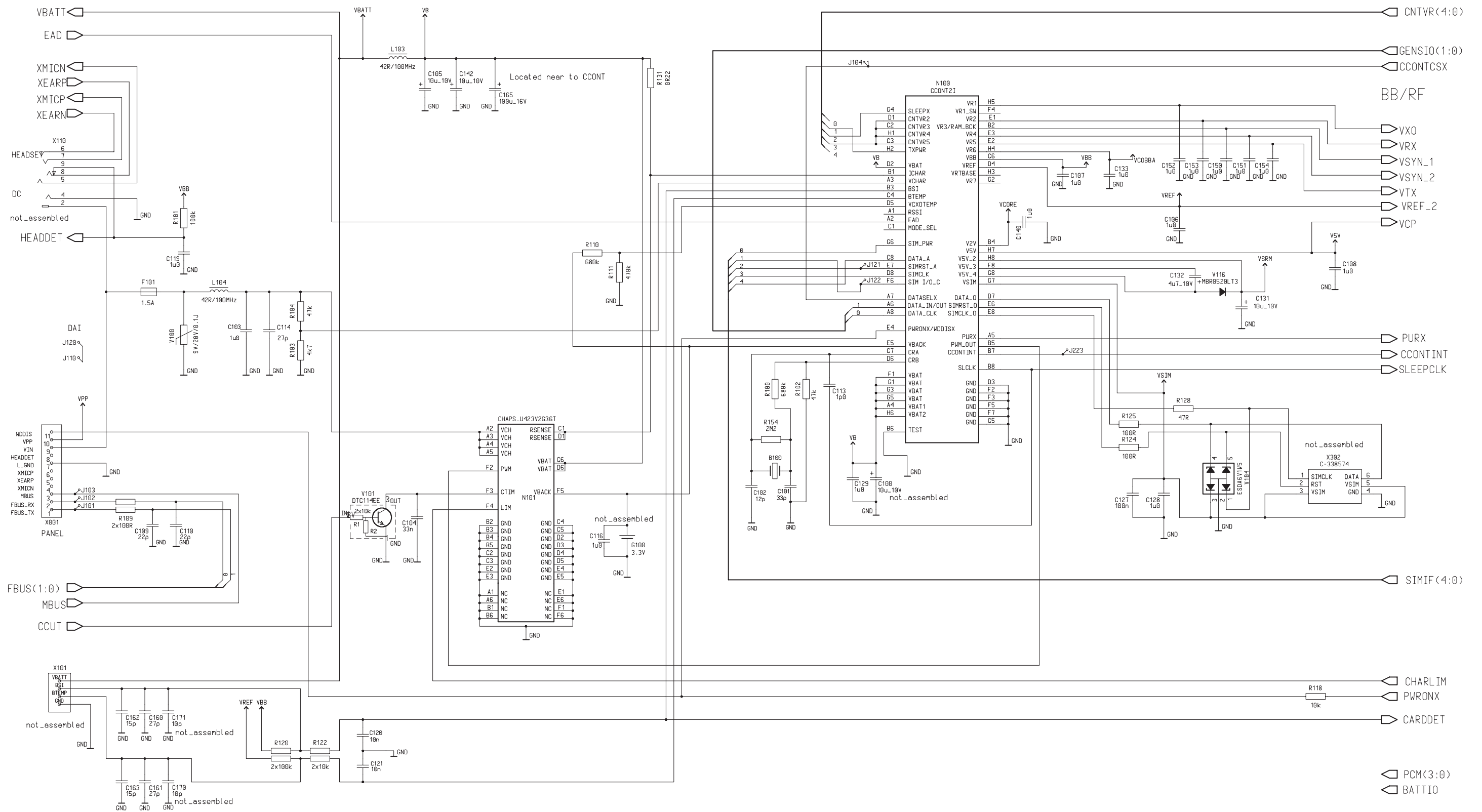

**Circuit Diagram of CPU Block** (Version 0410 Edit 4) for layout version 19

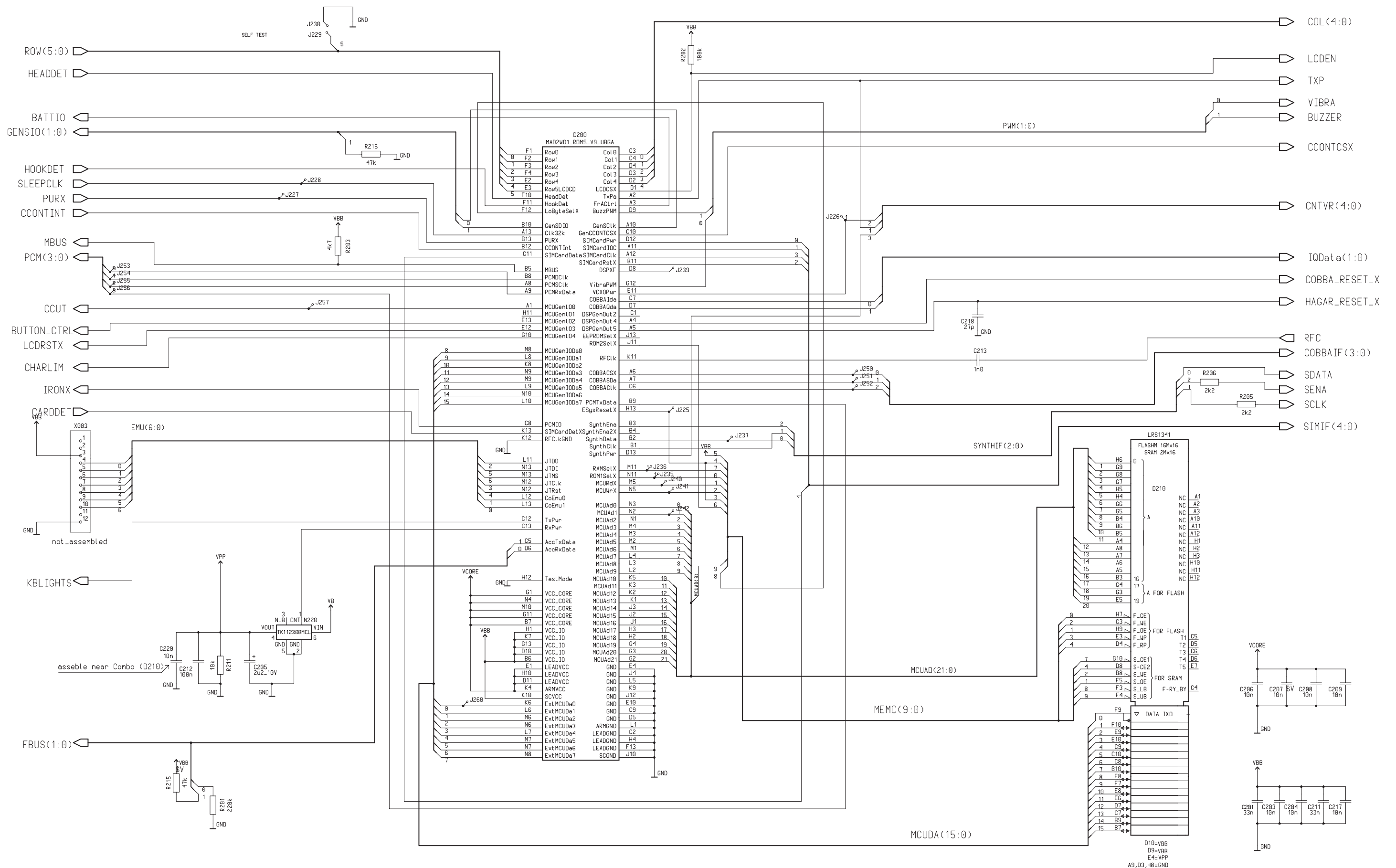



**Circuit Diagram of Audio and RFI** (Version 0410 Edit 2) for layout version 19

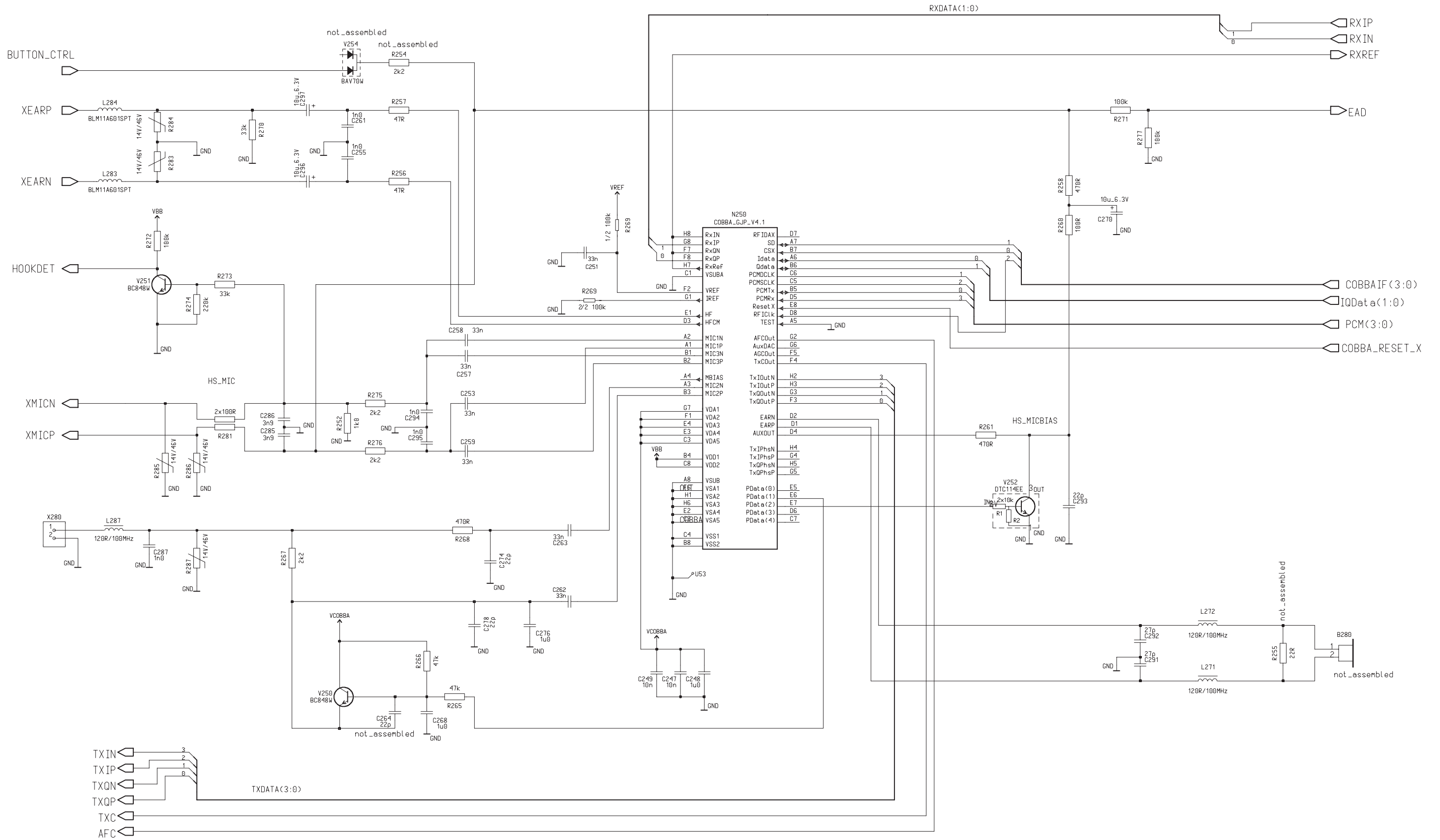

Circuit Diagram of IR Module (Version 0410 Edit 2) for layout version 19

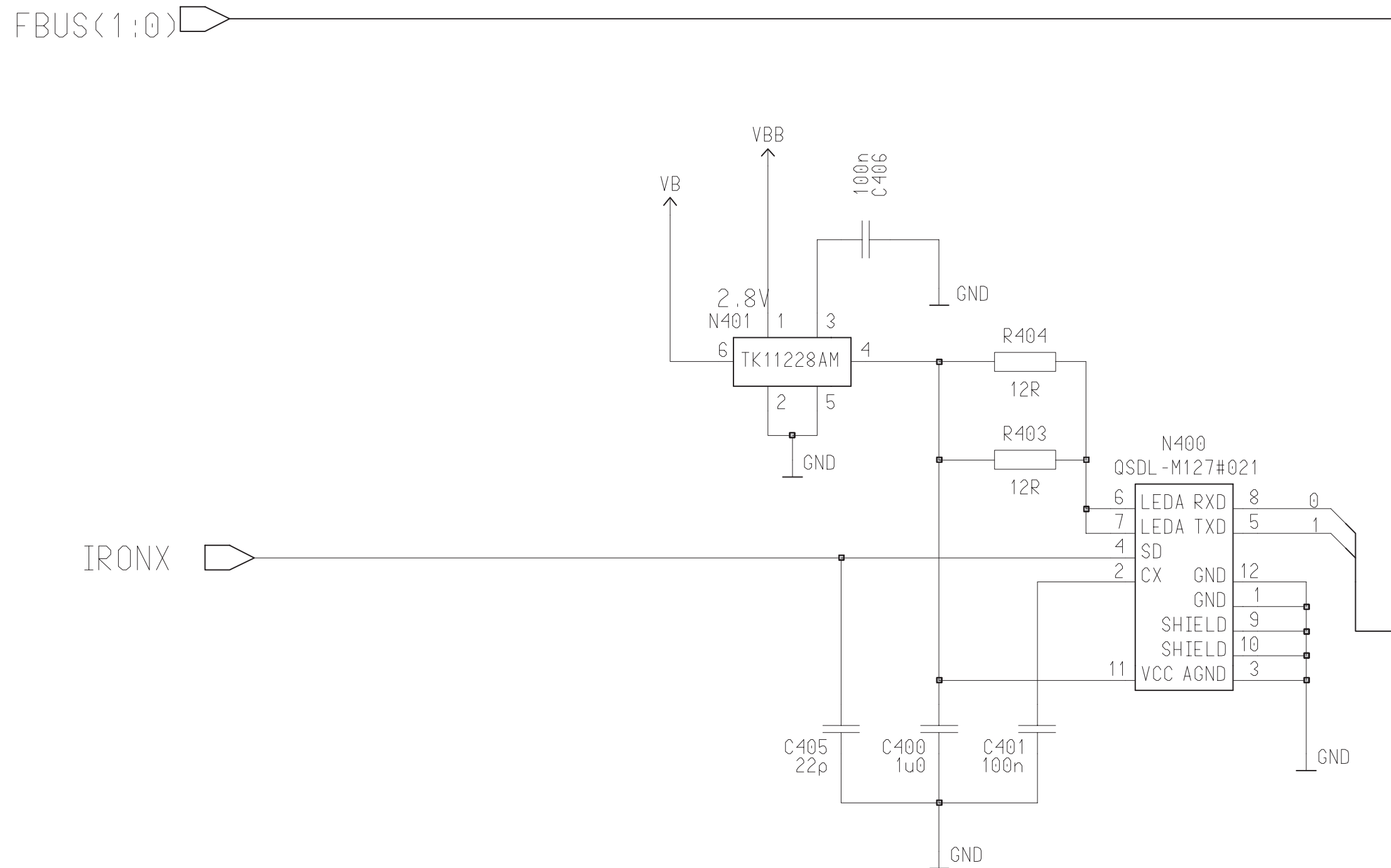

**Circuit Diagram of UIF** (Version 0410 Edit 2) for layout version 19

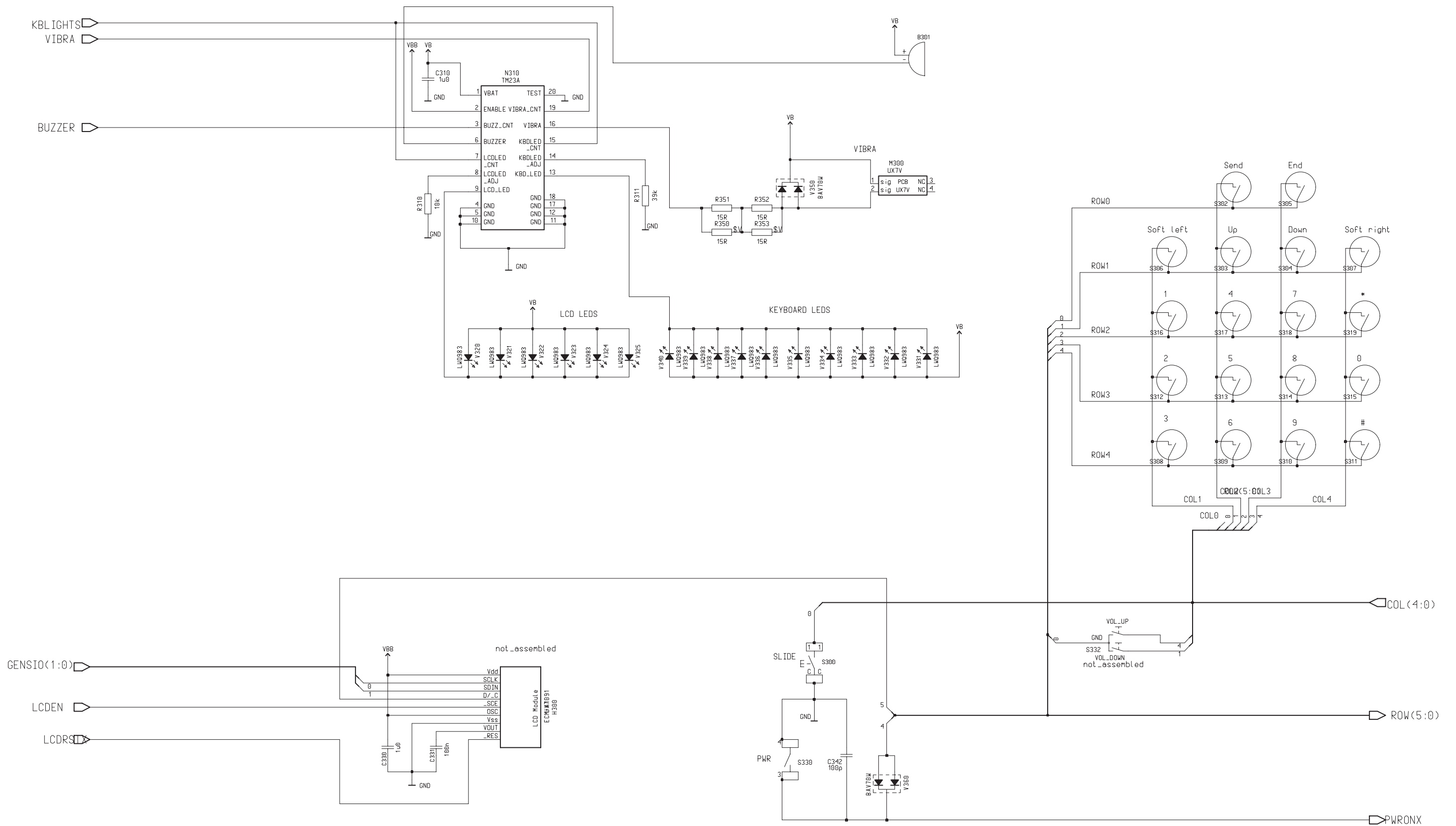



**Layout Diagram of RM7 – Top** (Version 19)

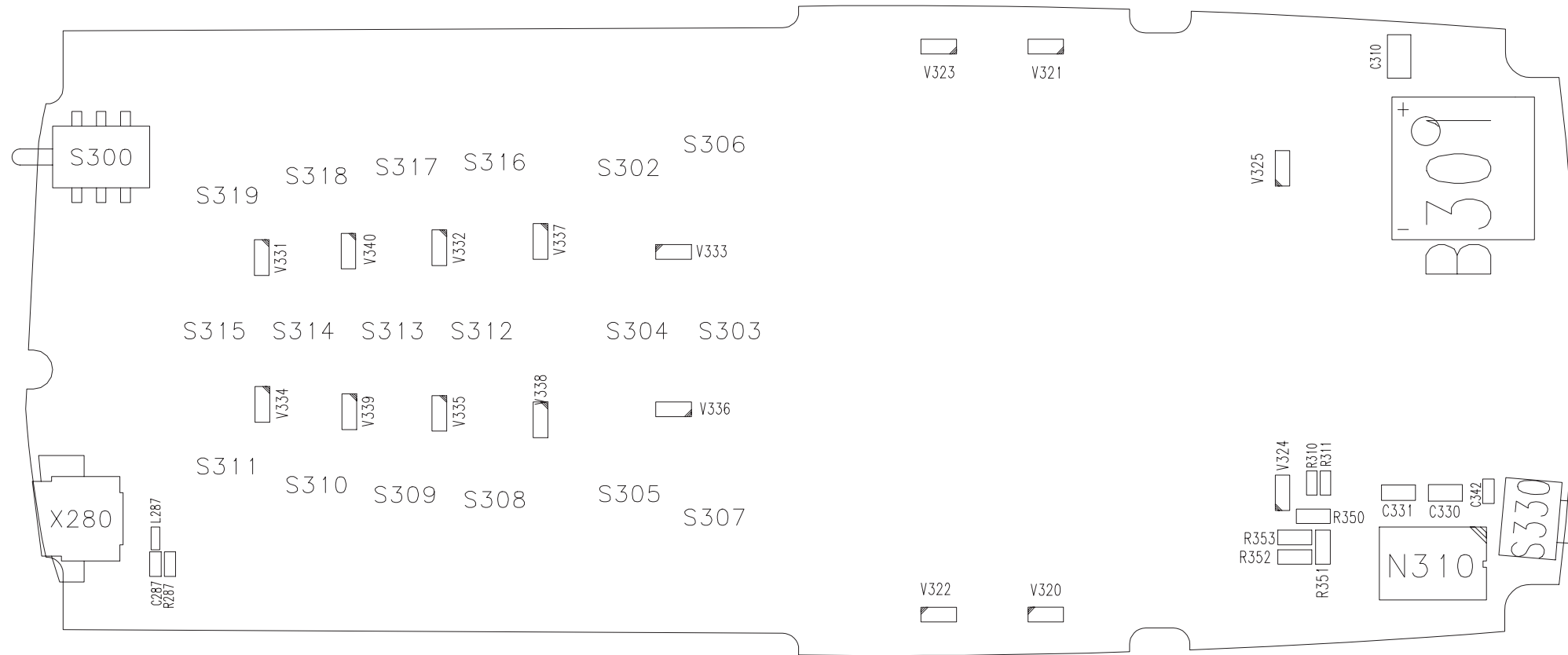

**Layout Diagram of RM7 – Bottom** (Version 19)

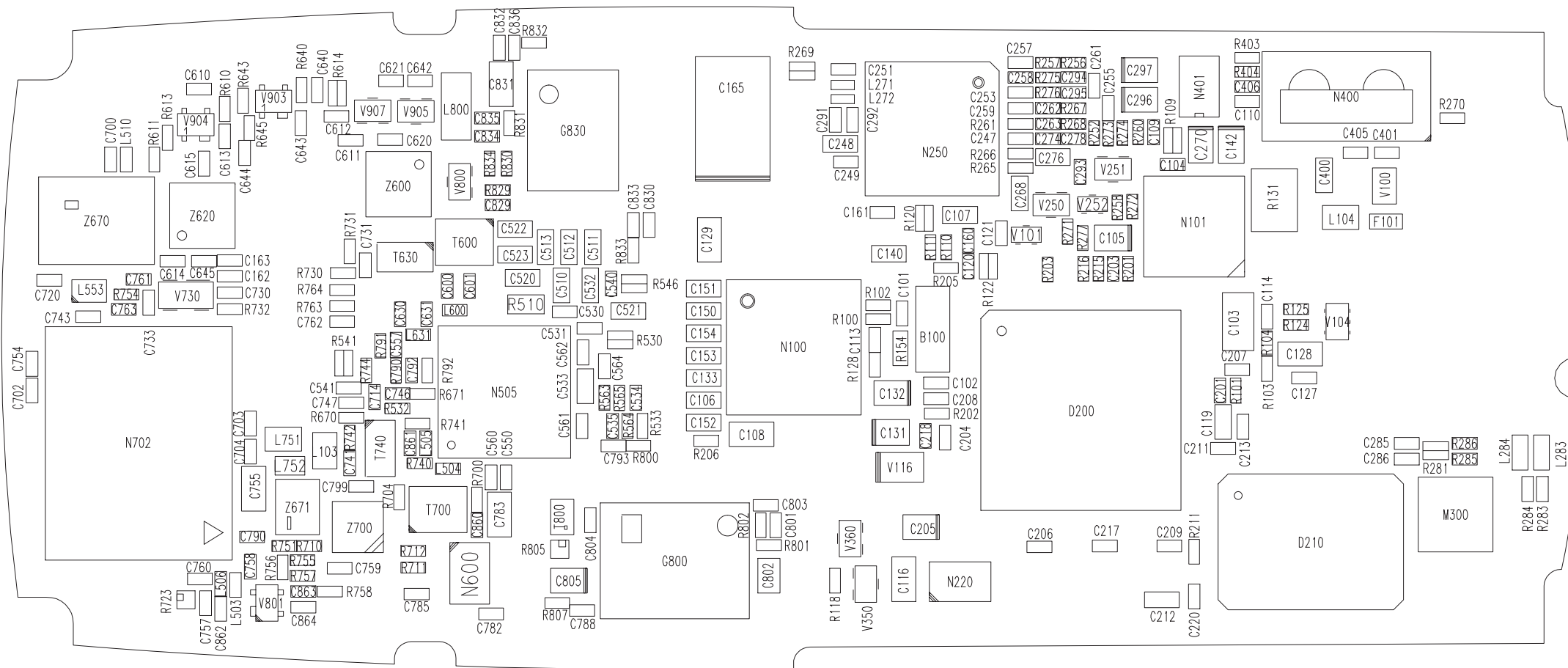

Testpoints of RM7 – Top (Version 14)

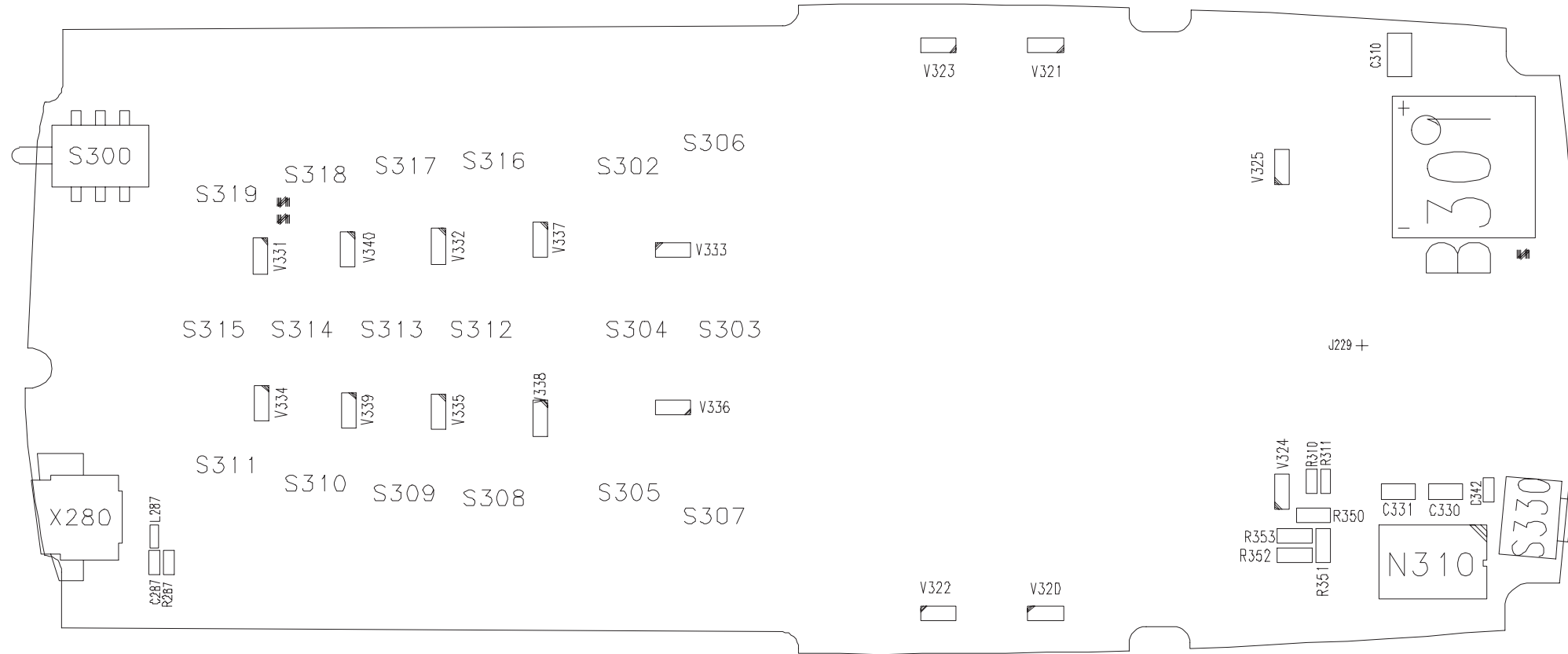

Testpoints of RM7 – Bottom (Version 19)

